

PRODUCT DATA SHEET

CLA INOX250A1 • 807735



BRAND



PRODUCT DETAILS

ClayTech Management Systems (CMS) provide the convenience of automatic selection between your water tank and mains supply, with the emphasis on maximizing the use of your rain water, with no power or additional wiring required. When tank water is available, the CMS will automatically choose to draw water from this source using the pump to deliver your water requirements.

CMS will automatically select to supply from your water tank as soon as rain water is available again.

The CLA-CMS valve has proven to be the most reliable mains water diversion valve on the Australian market. It is of nickel plated brass construction, hydraulically operated with full port flow and pressure when it switches to mains.

BENEFITS

- Self priming enables the pump to draw reliably from water lower than the pump inlet
- High flow, flat consistent performance curve.
- Complies with AS/NZS 4020 requirements

FEATURES

- Multi-stage pump
- Quiet, reliable operation
- Designed for larger homes
- Self-Priming
- Automatic Operation - adjustable start pressure
- Controller includes a pressure gauge
- Inbuilt dry run protection

PUMP TECHNICAL DATA

P1 RATED POWER (W)	985W
MAX. FLOW [LPM]	100 lpm
MAX. HEAD [M]	60m
WORKING TEMPERATURE	< 40°C
LIQUID TEMPERATURE	2°C - 35°C
MAX. WORKING PRESSURE	6 Bar
MOTOR DUTY	S1 Continuous
MOTOR PROTECTION LEVEL	Class F
PUMP BODY	Technopolymer
DIFFUSER MATERIAL	Technopolymer
MOTOR PROTECTION	In-built auto re-setting thermal overload
CAPACITOR	20.0 uF +/-5% 450V

RATED VOLTAGE	220V-240V 50 Hz
RATED CURRENT	5.5A @ 230V
POWER CABLE TYPE	2m H07RN-F
PROTECTION CLASS	IPX4
INLET	1" BSPF
OUTLET	1" BSPF
MECHANICAL SEAL	Carbon/Ceramic
MOTOR SHAFT	Stainless Steel
IMPELLER MATERIAL	Stainless Steel
AUTOMATION FUNCTION	No - bare pump only
NET WEIGHT (KG)	Pump only 13.0 kg
PACKAGE DIMENSION	570Lx270Wx350H (mm)

HYDRAULIC PERFORMANCE

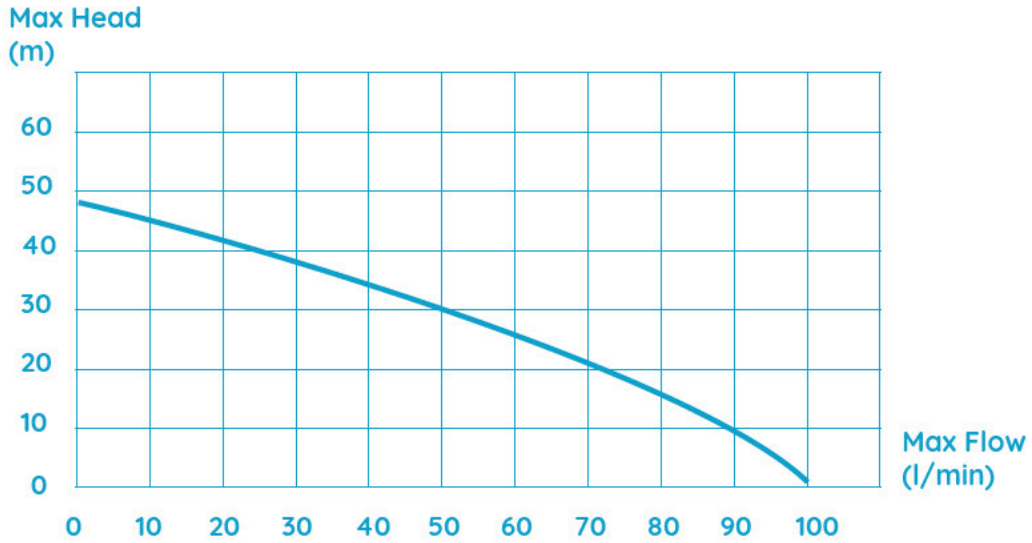

DIMENSIONS

INLET / OUTLET

1" BSPF

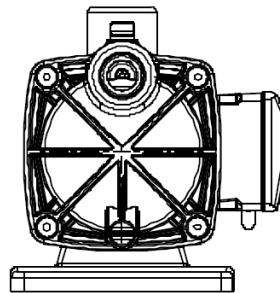
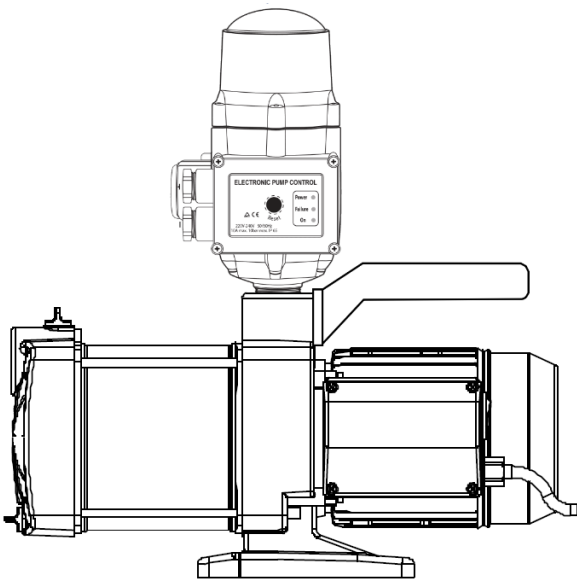
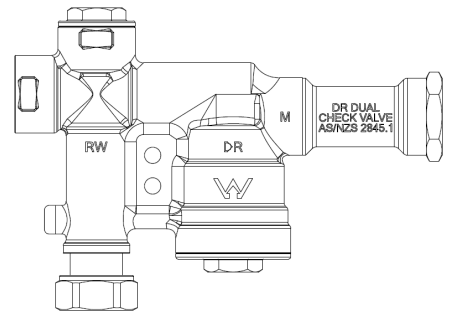

CMS SPECS

Max Mains pressure 1050kPa
Max Pump Pressure 1050kPa
Max flow 200LPM
Inlet/Outlet 1" BSPF
Weight 1.9kg

DIMENSIONS

Pump Only: 500 mm long, 220 High, 215mm wide
With controller: 450mm high

BASE FOOT

170 mm long, 275mm wide

WARRANTY / CERTIFICATIONS

